

SYNCHRONISATION OF STRATIGRAPHIES: ASHKELON AND TELL EL-DAB^{ca}

By Manfred Bietak, Karin Kopetzky, Lawrence E. Stager and Ross Voss

In the frame of the SCIEM 2000 project a special study concentrates on the synchronisation of the relative chronologies of Tell el-Dab^{ca}, situated in the north-eastern Nile delta and key sites in the Syro-Palestinian area, mainly the Levantine coast. One of these key sites is Ashkelon, where, in recent years, the Leon Levy Expedition sponsored by Harvard University has excavated a well controlled stratified sequence of Middle Bronze Age layers. The main tool for this project is the ceramics found at both sites, with small finds sometimes taken into consideration.

The material from Ashkelon comes from the stratigraphically well defined gate phases (STAGER 2002; VOSS 2002) as well as from settlement layers and tombs.¹ It has been compared to the stratified material from the layers of the late 12th dynasty until the early New Kingdom of Tell el-Dab^{ca} (BIETAK 1991; 1996; 1997; 2002). Although each site belongs to a different cultural province of the Middle Bronze Age, there was enough material common to both sites to make valid chronological comparisons. Especially helpful were imports from the northern Levant, Cyprus and the Aegean, which complemented the combination of artefacts of local material cultural assemblages. Also important for synchronisation were Egyptian exports which appeared in Ashkelon from the early 13th dynasty onwards.

Another important group for synchronising the layers of these two sites were Egyptian clay sealing of the late 12th and early 13th dynasty found in the oldest moat of the MB IIA gate of Ashkelon, which was filled between the phases 14 and 13 (STAGER 2002). Again the site of Tell el-Dab^{ca} provided good parallels for these pieces.

ASHKELON PH. 14 = TD PHASES H–G/4 (Fig. 1)

The pottery material from the phases H and G/4 is dated into the advanced MB IIA period. It is partly mirrored in the pottery repertoire of the oldest city gate and rampart phase from Ashkelon. Types such

as the Canaanite storage jars with simple everted rims (Fig. 1.2, 6) seem to be typical for the earlier Palestinian MB II A period. They were found at the key site of Tel Aphek mainly in the phases 1 and 2. While the storage jars with the elongated everted rim (Fig. 1.3, 7) appear a little bit later in the MB IIA sequence and last long into the MB IIB and C periods, where during the span of time a decline of the occurrence of this rim type is clearly visible. Collar-neck (collar) juglets (Fig. 1.1, 5) are attested in Tell el-Dab^{ca} for the first time in Ph. G/4, while the handmade flat bottom cooking pots (Fig. 1.4, 8) are present with the first appearance of the new immigrants in ph. H. Phase 14 of Ashkelon covers all these types and therefore indicates that this phase had a longer duration. While in Ashkelon in this phase Middle Cypriote White Painted III–IV Cross Line Style Ware was found, Tell el-Dab^{ca} sees the first appearance of Tell el-Yahudiyah Ware. The bulk of the settlement material from Ashkelon is firmly embedded in the southern Palestinian pottery tradition, Tell el-Dab^{ca} seems to have been more closely connected to regions further north during in this period.

ASHKELON MOAT DEPOSIT (MD), PH. 14/13 = TD PHASES G/4–G/1–3 (Figs. 1, 2)

The filling of the moat of the gate between the phases 14 and 13 at Ashkelon contained besides a large group of pottery, seal impressions of Egyptian scarabs of the late 12th and early 13th dynasty of local production (Fig. 1.9, 13).² Fragments of Kamares ware (Fig. 1.10, 14) as well as bichrome Levantine painted Ware (Fig. 2.5, 13) were found in this deposit. While in Tell el-Dab^{ca} the latter appear in the ph. H and G/4, the Kamares Ware is restricted to phase G/4. Early Tell el-Yahudiyah ware with handmade (not with the help of a comb) incrustations (Fig. 2.1, 2, 9, 10) were found in both places in this period. Large water containers made of Marl C fabric, called *zirs* (Fig. 2.8, 16) are a typical settlement vessel of the Middle Kingdom and the Second Intermediate Period. Rim fragments of

¹ The settlement and tomb material came mainly from grids 38 and 50.

² Lanny Bell is studying and publishing this group of sealings.

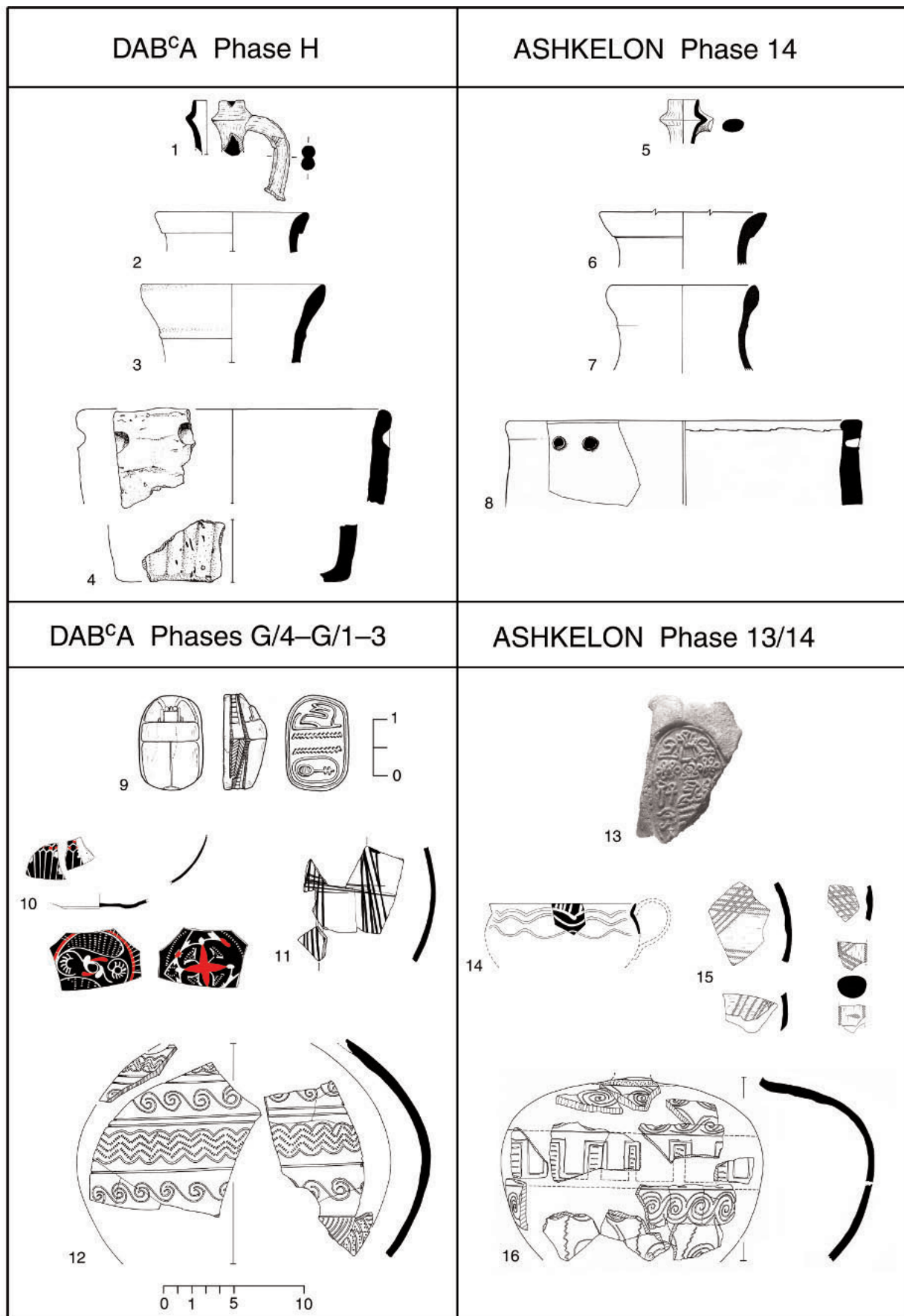

Fig. 1 Important common features between Tell el-Dab^ca, phase H and Ashkelon phase 14 and Tell el-Dab^ca phases G/4 and G/1–3 and the Moat Deposit in Ashkelon between the phases 14 and 13

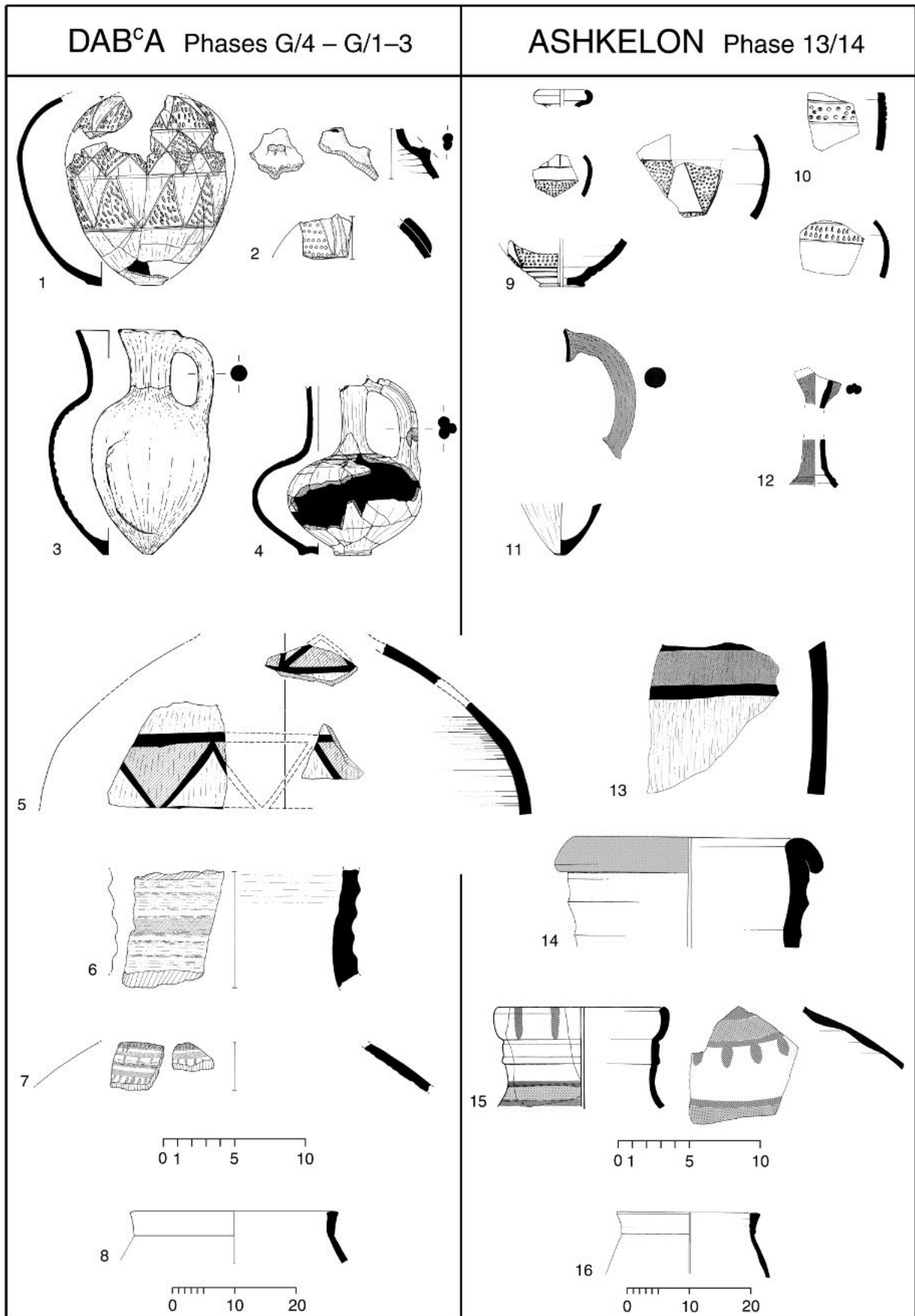

Fig. 2 Important common features between Tell el-Dab^a, phases G/4 and G/1–3 and the Moat Deposit in Ashkelon between phases 14 and 13

these jars were found in the different phases of Ashkelon. It is the rims of these jars that show a chronologically relevant development. Zir type 4 with its folded lip and the horizontally trimmed rim appears in Tell el-Dab^ca for the first time in phase G/4. Dipper juglets are attested already in the phases of ^cEzbet Rushdi, though these early examples were horizontally combed, never burnished and equipped with a round base. It is in ph. G/4 that the first red burnished dipper juglets with a blunt base (Fig. 2.3, 11) appear. Large red burnished shoulder-handled jugs with double ridged handles are found in this and the following period. About the same size have large jugs decorated in the Tell el-Yahudiyah style with spirals (Fig. 1.12, 16), which occur at both sites. For the first time in phase G/1–3 juglets of the Tell el-Yahudiyah group piriform 1a and 1b (Fig. 2.1, 9) were found parallel with the Middle Cypriote White Painted III–IV Wares of Cross Line Style (Fig. 1.11, 15). This phase sees also the first appearance of Red, White and Blue Ware (Fig. 2.7, 15) and of brown burnished jugs with cut spouts and double or tripartite handles (Fig. 2.4, 12) at the site. Ridged neck pithoi (Fig. 2.6, 14) are, until now, known only from Ashkelon and Tell el-Dab^ca, on the latter site exclusively from ph. G/1–3.

ASHKELON PH. 13 = TD PHASES G/1–3

The second city gate of Ashkelon, ph. 13 and ph. G/1–3 of Tell el-Dab^ca besides the earlier material of the moat deposit, provide the first appearance of burnished juglets with button base, small red burnished globular cups, carinated bowls with either a sharp or round carination.

ASHKELON PH. 12 = TD PHASE F–E/3 (Figs. 3, 4)

The Cypriote material of the third city gate at Ashkelon and ph. F at Tell el-Dab^ca contains, besides the continuation of the White Painted III–IV Cross Line Style, for the first time vessels of the White Painted III–IV Pendent Line Style and the Middle Cypriote Red on Black ware (Fig. 3.1, 7). Red burnished dipper juglets (Fig. 3.2, 8) and carinated bowls (Fig. 3.3, 9) appear again at both sites. Burnished bowls with inverted rims and a red-cross decoration on the interior (Fig. 3.10) have their first appearance in ph. F in Tell el-Dab^ca. They appear in Ashkelon for the first time at the end of phase 13 and seem to be a marker of the beginning of the MB IIB period. Bowls with ledge handles (Fig. 3.5, 11) were found in Tell el-Dab^ca mainly in

the first half of the MB IIB period, beginning with the first examples in ph. F, the transitional MB IIA/B phase. Burnished jars, mainly in red (Fig. 3.6, 12) are attested in the gate area of Ashkelon for the first time in ph. 12, in Tell el-Dab^ca they appear already at the end of phase G/1–3. Large globular bowls with knobs (Fig. 4.13, 19) were found in Tell el-Dab^ca only in ph. F, while in Ashkelon they appear already in earlier phases. Red burnished globular bowls either with a simple rim (Fig. 4.14, 20) or with an everted one (Fig. 4.15, 21) are typical in Tell el-Dab^ca for the phases F and E/3, in Ashkelon they exist from phase 13/14 onwards. Wheel-made MB cooking pots with gutter rims (Fig. 4.16, 22) were found on both sites during this period. Ph. 12 sees the first appearance of large Canaanite storage jars with nail shaped rims (Fig. 4.17, 23), which were established in Tell el-Dab^ca for the first time in ph. G/1–3. The import of Marl C zirs of rim type 4 is again proven for this phase.

ASHKELON PH. 11 = TD PHASE E/2–D/3 (Figs. 5, 6)

In this phase the main city gate was moved and a much smaller footgate was carved into the much larger city gate of ph. 12. In the gate area seemed to exist a local gap, which is covered by material from other excavated areas. Cypriote Red on Black Ware (Fig. 5.1, 7) and White Painted III–IV types continue and for the first time White Painted V Ware (Fig. 5.2, 8) appears, which is found in Tell el-Dab^ca from ph. E/1 onwards. Ashkelon receives Egyptian imports, such as Marl C zirs of rim type 5 (Fig. 6.14, 16), large globular Tell el-Yahudiya jugs (Fig. 5.4, 10), biconical Tell el-Yahudiya juglets (Fig. 5.3, 9) and wheel-made sand-tempered (Nile E2 fabric) cooking pots (Fig. 5.6, 12). On the whole the two sites have a relatively small group of Palestinian types in common. There are small burnished juglets with rims rolled to the outside and double-ridged handles, brown burnished bowls with upright rims (Fig. 5.5, 11) and MB II wheel-made cooking pots (Fig. 6.13, 15).

ASHKELON PH. 10 = TD PHASE D/3–D/1 (Figs. 7, 8)

In terms of the MB chronology ph. 10 covers more or less the MB IIC period. In terms of Egyptian chronology this equates with the last phase of the Hyksos period and the beginning of the New Kingdom. Within this period both cities imported White Painted III–IV Wares of the Cross Line and Pendant Line Style as well as White Painted V Ware

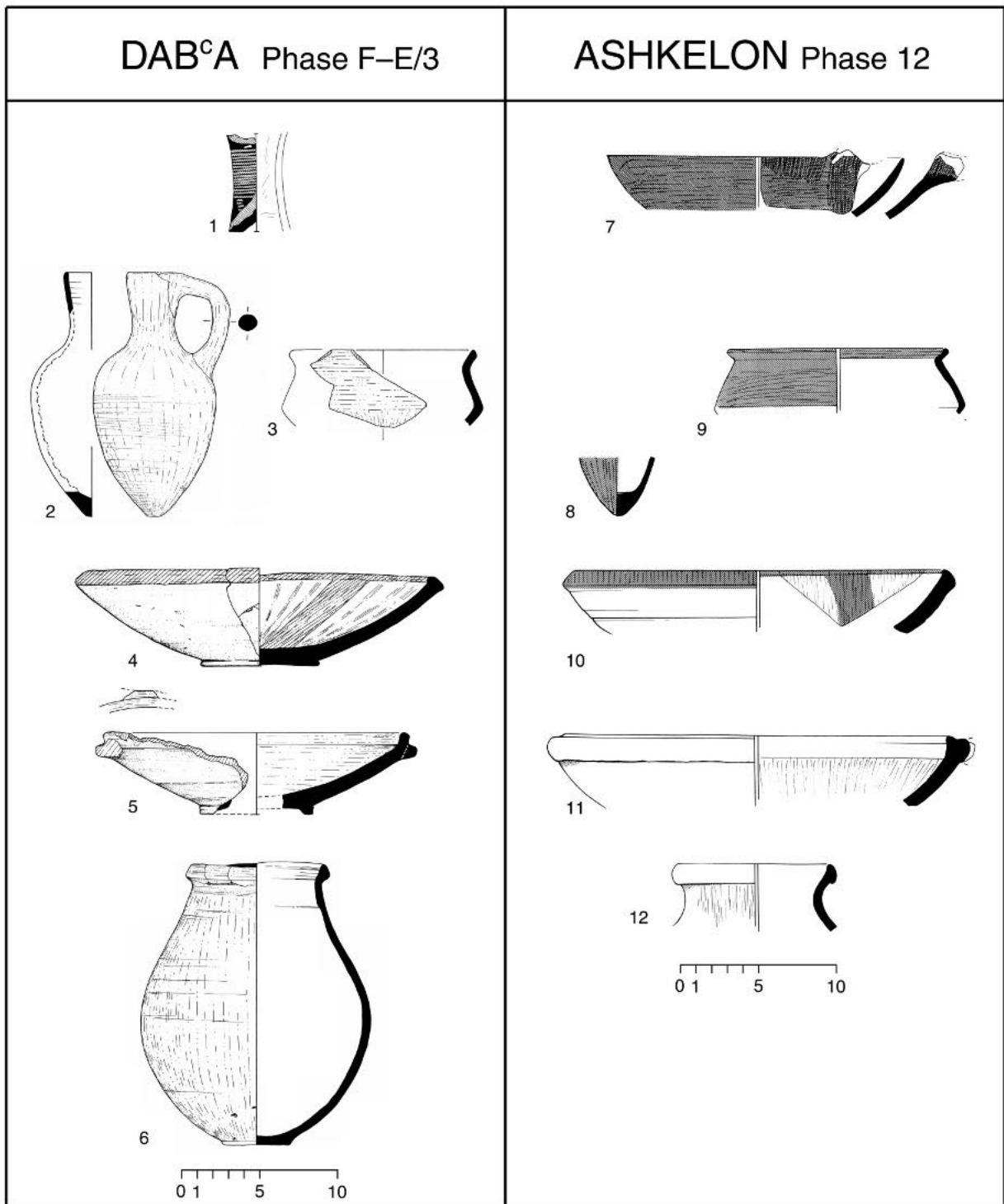

Fig. 3 Important common features between Tell el-Dab^a phase F and E/3 and Ashkelon phase 12

(Fig. 7.1, 5). Typical for the late Hyksos layers are black burnished biconical Tell el-Yahudiyah juglets (Fig. 7.2, 6), round bottomed wheel-made cooking pots (Fig. 8.10, 14) and gritty Marl C zirs with rim type 5 (Fig. 8.12, 16). From this phase come also vessel types that belong already in the early 18th dynasty and were imported from Egypt, such as a

cup (Fig. 7.3, 7) and a jar (Fig. 8.9, 13), whose horizontally trimmed rim possesses a groove that is running on top of the rim. Both were produced of Nile B2 clay, which showed the typical sandy tempering of the New Kingdom. But also local productions of Egyptian vessels imitating Egyptian fabrics were found at Ashkelon. There are fragments

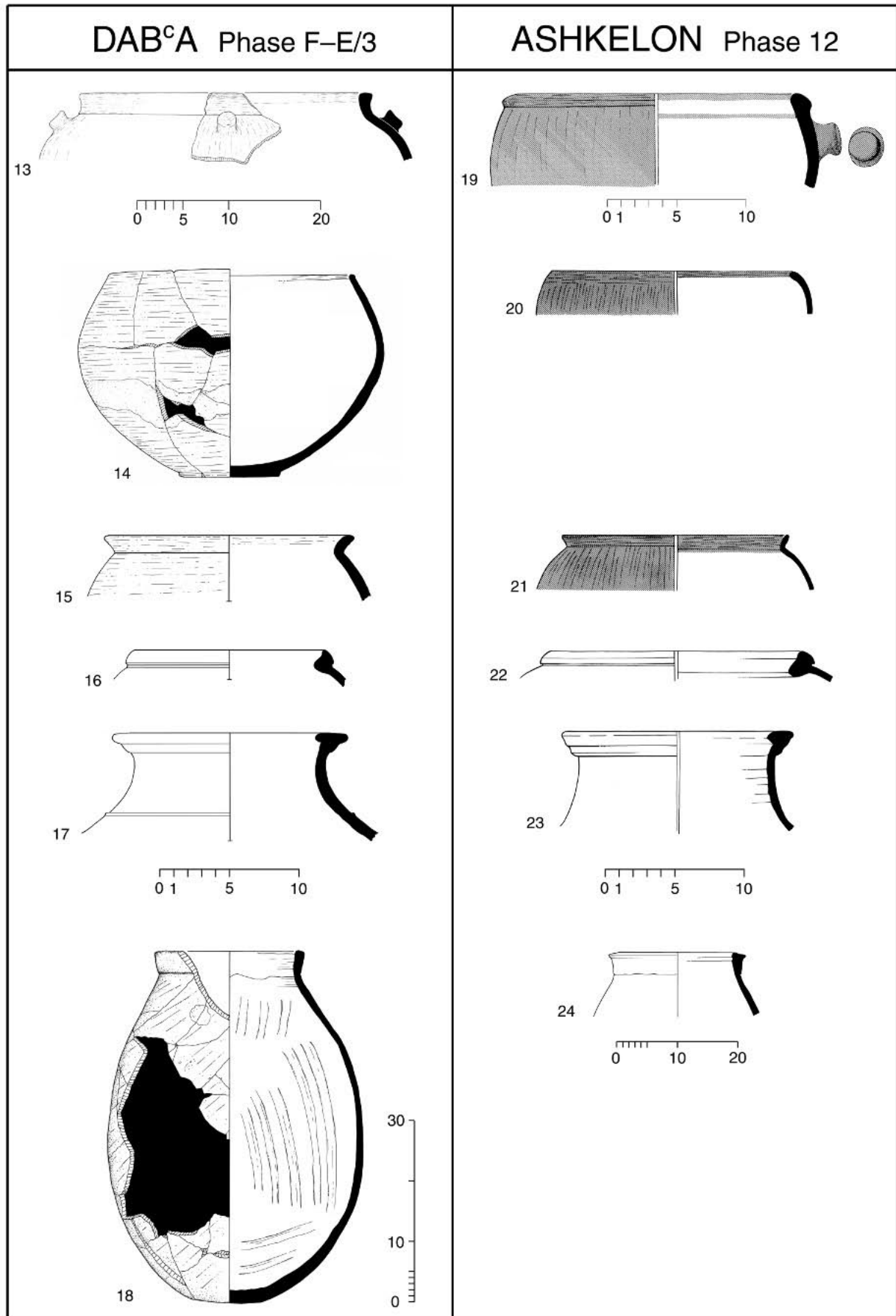

Fig. 4 Important common features between Tell el-Dab^ca phase F and E/3 and Ashkelon phase 12

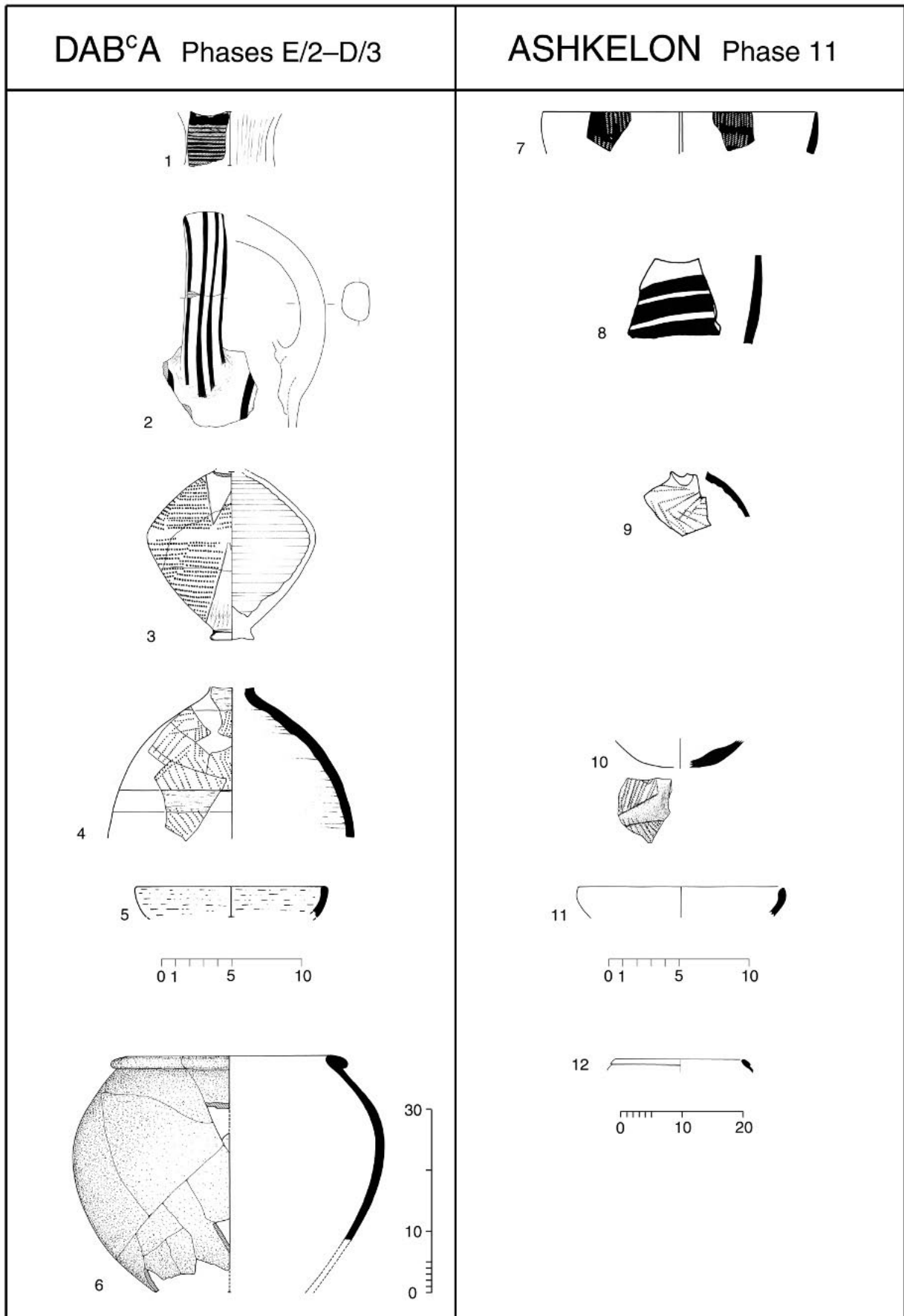

Fig. 5 Important common features between Tell el-Dab^a phase E/2 and D/3 and Ashkelon phase 11

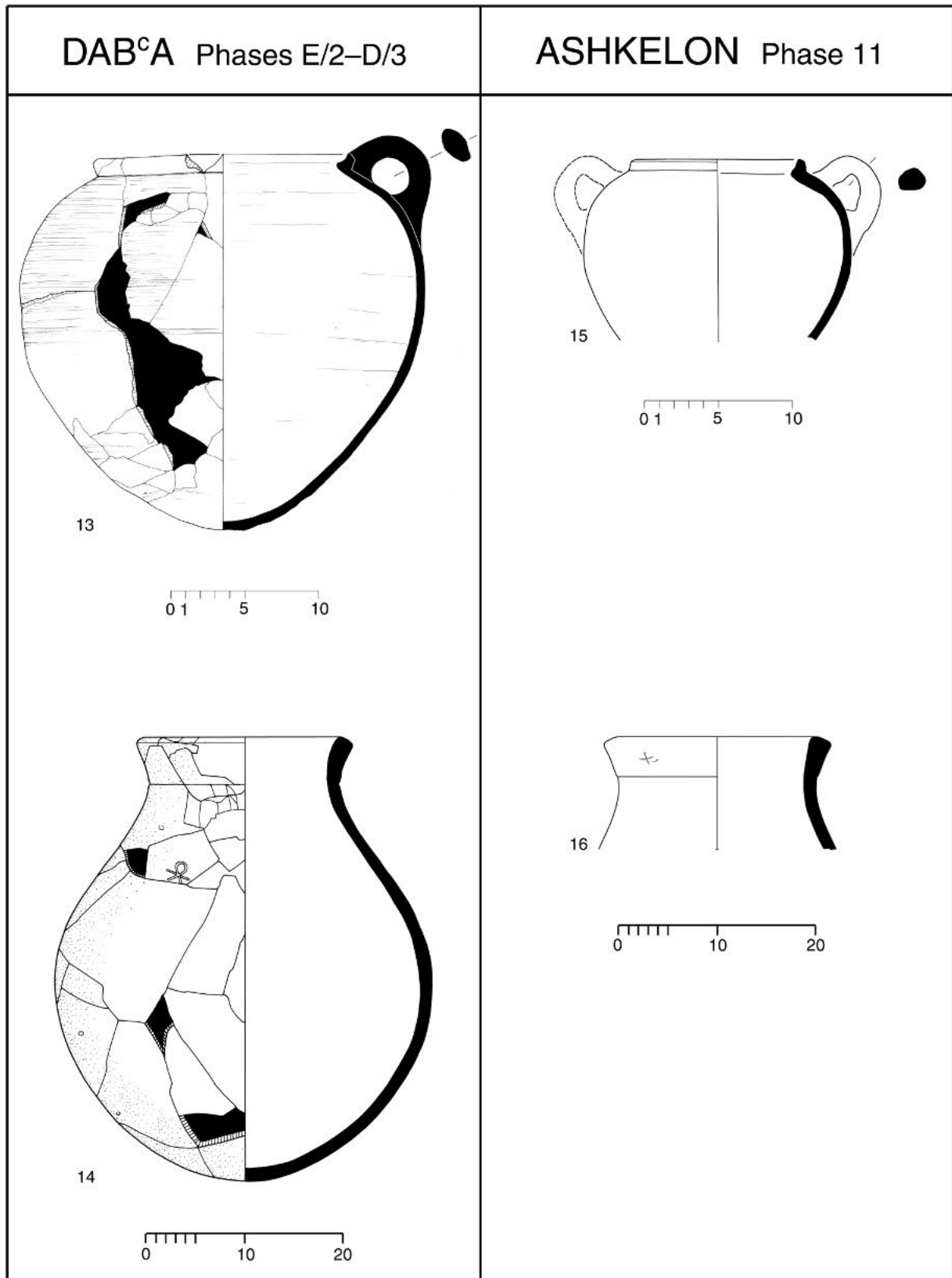

Fig. 6 Important common features between Tell el-Dab^ca phase E/2 and D/3 and Ashkelon phase 11

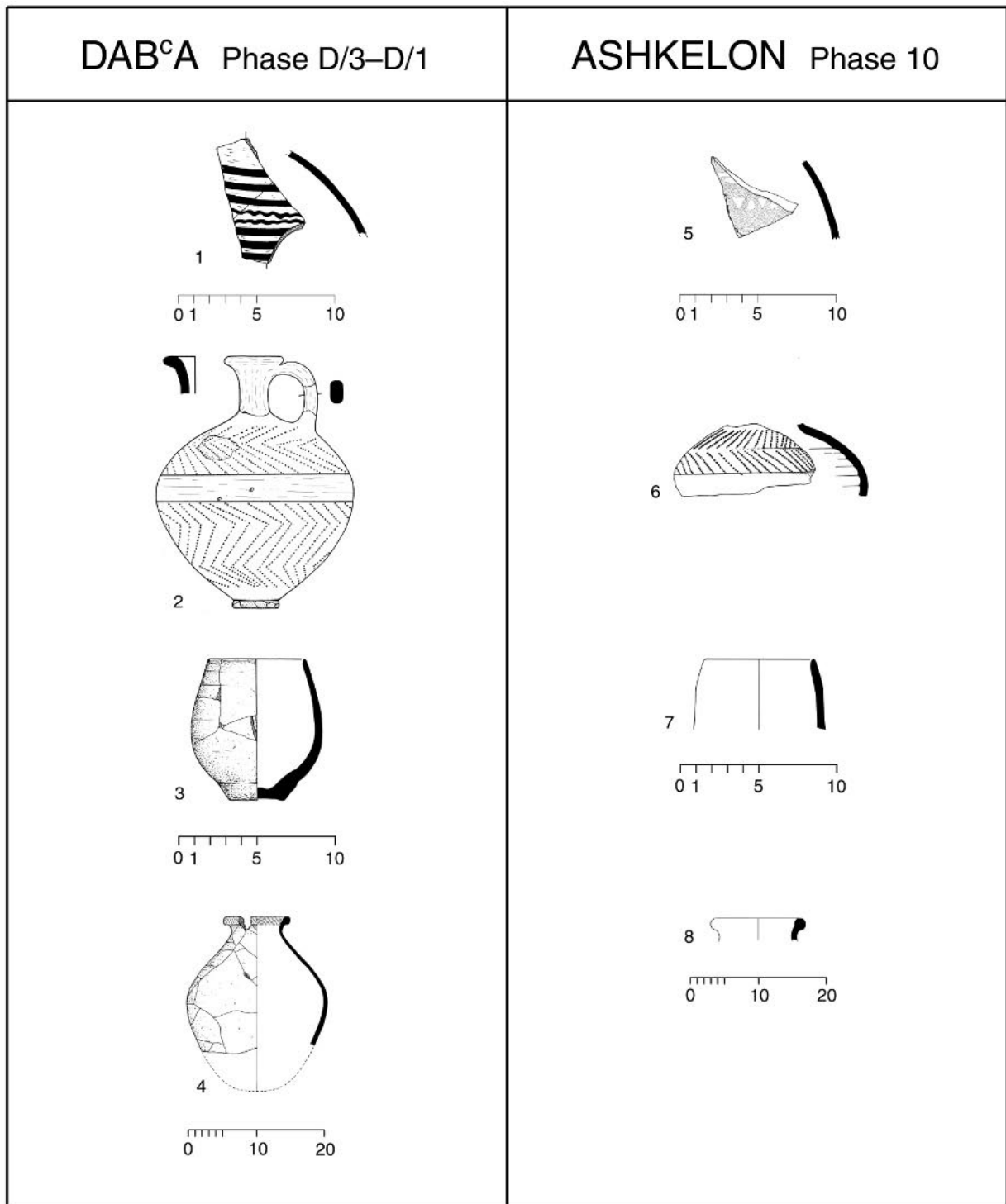

Fig. 7 Important common features between Tell el-Dab^a phase D/3 and D/1 and Ashkelon phase 10

of a jar with its rim rolled to the inside (Fig. 7.4, 8), a type that exists in Tell el-Dab^a from the Hyksos period into the 18th dynasty levels. The rim fragment of a wheel-made cooking pot with an upright rim can not be found in Tell el-Dab^a before the beginning of the New Kingdom (Fig. 8.11, 15).

From the late MB IIC burials of this phase come also fragments of Cypriote bichrome vessels.

CONCLUSION (Fig. 9)

Looking at the ceramic evidence and certain groups of small finds it was possible to synchro-

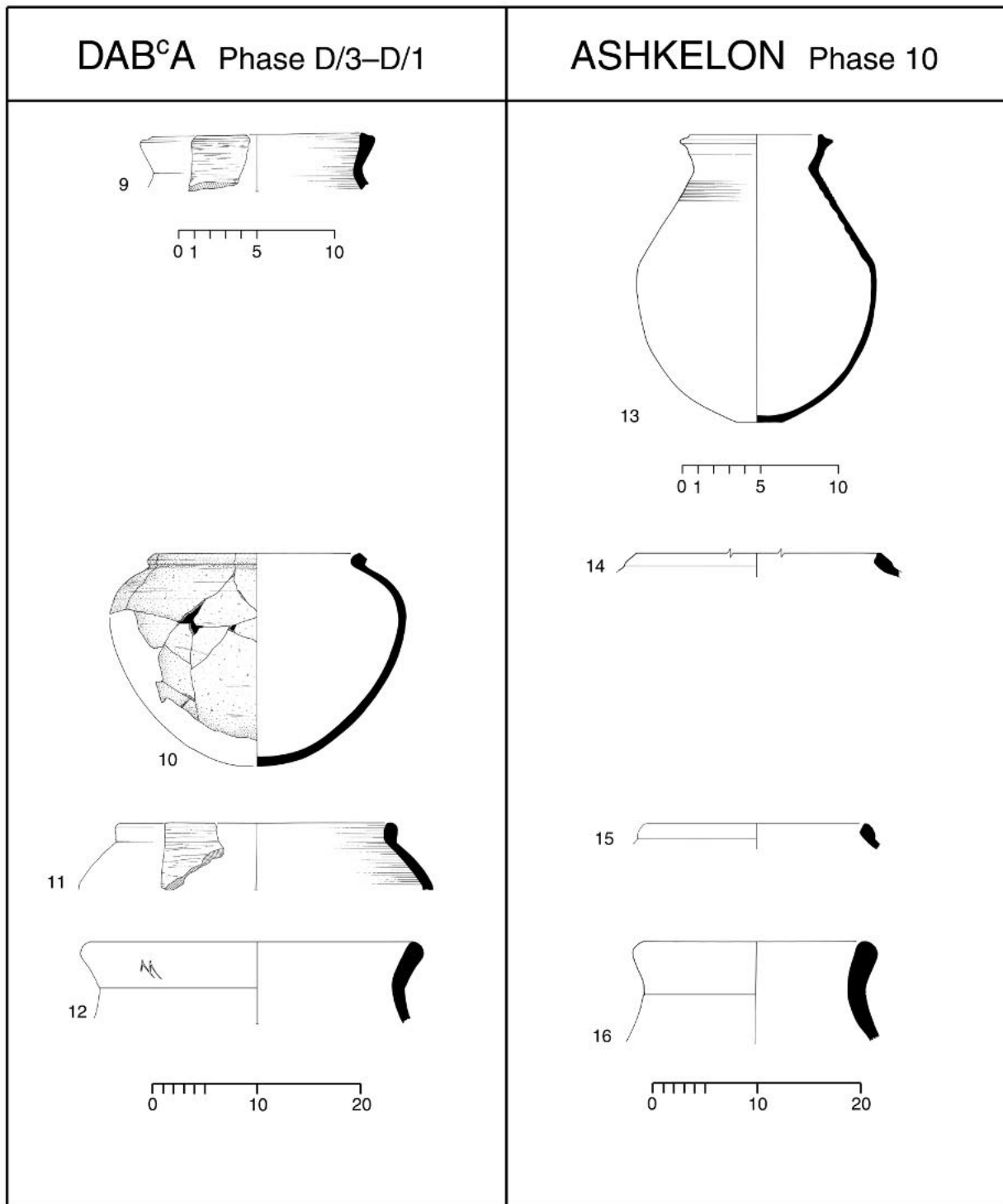

Fig. 8 Important common features between Tell el-Dab^ca phase D/3 and D/1 and Ashkelon phase 10

nise the MB phases of the two cities. It seems from today's perspective that the settling of the MB population in Tell el-Dab^ca and the construction of the massive fortifications at Ashkelon began about the same time, sometime in the first half of the MB IIA period. A connection between Egypt

and Ashkelon in the early 13th dynasty is evident by the import of Egyptian pottery and the use of Egyptian scarabs found as impressions on sealing from the deposit of the oldest moat of Ashkelon. The material culture of ph. 12 and the equivalent ph. F and E/3 of Tell el-Dab^ca show the best cor-

respondence in the settlement material between these two sites. In the following MB IIB period their cultural development differs considerably. Only types that have a wide distribution along the Levantine coast such as Tell el-Yahudiyah ware and Cypriote imports were in common. Egyptian Marl C zirs most probably used as containers for shipping commodity only occasionally reached Ashkelon. A local production of Egyptian cooking

pots is attested for this period. Although with the beginning of the New Kingdom both sites continued with their local pottery traditions, it is obvious that the contact between Egypt and the southern Palestinian region intensified again. This can be seen by early 18th dynasty imports found in the MB IIC settlement and tombs of Ashkelon. It is the same period which provides the first Late Cypriote imports at both sites.

B. C.	TELL EL-DAB ^a	ASHKELON
1500	D/1.1	10
	D/1.2	
	D/2	
1600	D/3	11
	E/1	
	E/2	
1700	E/3	12
	F	
	G/1-3	13
	G/4	13/14
1800	H	14

Fig. 9 Synchronisation table between the stratigraphies of Tell el-Dab^a and Ashkelon

Bibliography

- BIETAK, M.
 1991 Egypt and Canaan during the Middle Bronze Age. *BASOR* 281: 27–72
 1996 *Avaris, The Capital of the Hyksos – Recent Excavations at Tell el-Dab^a*. The First Raymond and Beverly Sackler Foundation Distinguished Lecture in Egyptology. London.
 1997 The Center of the Hyksos Rule: Avaris (Tell el-Dab^a), 87–139, in: E.D. OREN (ed.), *The Hyksos: New Historical and Archaeological Perspectives*, Uni-

- versity Museum Monographs 96, University Museums Symposium Series 8.
- 2002 Relative and Absolute Chronology of the Middle Bronze Age: Comments on the Present Stage of Research, 30–42, in: M. BIETAK (ed.), 2002.
- BIETAK, M. (ed.)
- 2002 *The Middle Bronze Age in the Levant. Proceedings of an International Conference on MB IIA Ceramic Materials in Vienna 24th–26th of January 2001*, CChEM 3, Vienna.
- BIETAK, M., FORSTNER-MÜLLER, I., and MLINAR, C.
- 2002 The Beginning of the Hyksos Period at Tell el-Dab'a, A Subtle Change in Material Culture, 171–181, in: P. FISCHER (ed.), *Contributions to the Archaeology of the Bronze and Iron Ages in the Eastern Mediterranean in Honour of Paul Åström*, Österreichisches Archäologisches Institut, Sonderschriften 39, Vienna.
- STAGER, L.E.
- 2002 The MBIIA Ceramic Sequence at Tel Ashkelon and its Implications for the “Port Power” Model of Trade, 353–363, in: M. BIETAK (ed.) 2002.
- VOSS, R.
- 2002 A Sequence of Four Middle Bronze Age Gates in Ashkelon, 379–384, in: M. BIETAK (ed.) 2002.